

Subject: Exhaust gas recirculation (EGR) system diagrams for 1996–2008 vehicles

Source: Ford service manuals

Use Table F083-1, “Passenger Car,” below and Table F083-2, “Truck, Van, and Sport Utility,” on page F370 to locate the wiring diagram for the vehicle being tested:

Table F083-1 Passenger Car (part 1 of 3)

MODEL	YEAR	ENGINE	CONNECTOR	FIGURE
Continental	1996–97	All	Vacuum regulator solenoid	Figure F083-13
	1996–2001	3.8L	Differential feedback EGR	Figure F083-1
	1998–2001	All	Vacuum regulator solenoid	Figure F083-13
Cougar	1996	All	Vacuum regulator solenoid	Figure F083-5
		4.6L	Vacuum regulator solenoid	Figure F083-13
	1996–97	3.8L	Differential feedback EGR	Figure F083-1
	1998–2001	All	Vacuum regulator solenoid	Figure F083-13
	2002	All	Differential feedback EGR	Figure F083-15
				Vacuum regulator solenoid
Contour, Mystique	1996–97	All	Vacuum regulator solenoid	Figure F083-13
Crown Victoria, Grand Marquis	1996–2001	All	Vacuum regulator solenoid	Figure F083-13
	2003–04	All	EGR system module (ESM)	Figure F083-24
	2005–06	All	EGR system module (ESM)	Figure F083-25
	2007–08	All	EGR system module (ESM)	Figure F083-26
Escort	1996	All	Vacuum regulator solenoid	Figure F083-5
	1996–2001	All	Differential feedback EGR	Figure F083-1
	1997	All	Vacuum regulator solenoid	Figure F083-13
	1998–2001	All	Vacuum regulator solenoid	Figure F083-13
	2002–03	All	Differential feedback EGR	Figure F083-15
			Vacuum regulator solenoid	Figure F083-16
Focus	2006–07	All	Electric EGR assmbly	Figure F083-27
	2008	All	Electric EGR assmbly	Figure F083-28
Fivehundred	2005–07	All	EGR system module (ESM)	Figure F083-29
Freestyle	2005–07	All	EGR system module (ESM)	Figure F083-29
Fusion	2006	All	Electric EGR assmbly	Figure F083-30

Table F083-1 Passenger Car (part 2 of 3)

MODEL	YEAR	ENGINE	CONNECTOR	FIGURE
Lincoln LS	1999–2001	All	Differential feedback EGR	Figure F083-2
			Vacuum regulator solenoid	Figure F083-14
	2004–05	with tube mounted DPFE sensor	Differential Pressure Feedback EGR	Figure F083-18 Table F083-3 Table F083-4
		without tube mounted DPFE sensor	Differential Pressure Feedback EGR	Figure F083-19 Table F083-3 Table F083-4
		with conventional EGR/EVR system	Vacuum regulator Solenoid	Figure F083-20 Table F083-3 Table F083-4
	2006	All	EGR system module (ESM)	Figure F083-22
Electric EGR assmby			Figure F083-23	
Mark VIII	1996–97	All	Vacuum regulator solenoid	Figure F083-13
Milan	2006	All	Electric EGR assmby	Figure F083-30
Montego	2005–07	All	EGR system module (ESM)	Figure F083-29
Mustang	1996	3.8L	Vacuum regulator solenoid	Figure F083-5
	1996–2001	All	Differential feedback EGR	Figure F083-1
	1997	All	Vacuum regulator solenoid	Figure F083-5
	1998–2001	All	Vacuum regulator solenoid	Figure F083-13
			Differential feedback EGR	Figure F083-15
	2002–03	All	Vacuum regulator solenoid	Figure F083-16
			Differential Pressure Feedback EGR	Figure F083-18 Table F083-3 Table F083-4
	2004–05	without tube mounted DPFE sensor	Differential Pressure Feedback EGR	Figure F083-19 Table F083-3 Table F083-4
		with conventional EGR/EVR system	Vacuum regulator Solenoid	Figure F083-20 Table F083-3 Table F083-4
		All	EGR system module (ESM)	Figure F083-22
Probe	1996–97	All	Atmospheric solenoid	Figure F083-7
			Vacuum regulator solenoid	Figure F083-8
			EGR check solenoid	Figure F083-9
			EGR valve position sensor	Figure F083-10
			Barometric sensor	Figure F083-11

Table F083-1 Passenger Car (part 3 of 3)

MODEL	YEAR	ENGINE	CONNECTOR	FIGURE
Taurus, Sable	1996–97	All	Vacuum regulator solenoid	Figure F083-13
	1996–2001	All	Differential feedback EGR	Figure F083-1
	1998–2001	Except 3.0L 4V	Vacuum regulator solenoid	Figure F083-13
	2000–03	All	Differential feedback EGR	Figure F083-15
	2002–03	All	Vacuum regulator solenoid	Figure F083-16
	2004–07	with tube mounted DPFE sensor	Differential Pressure Feedback EGR	Figure F083-19 Figure F083-20
		without tube mounted DPFE sensor	Differential Pressure Feedback EGR	Figure F083-19 Table F083-3 Table F083-4
		with conventional EGR/EVR system	Vacuum Regulator Solenoid	Figure F083-20 Table F083-3 Table F083-4
	Thunderbird	1996	All	Vacuum regulator solenoid
4.6L			Vacuum regulator solenoid	Figure F083-13
1996–97		3.8L	Differential feedback EGR	Figure F083-1
1998–2001		All	Vacuum regulator solenoid	Figure F083-13
2002		All	Differential feedback EGR	Figure F083-2
Town Car	1996–97	All	Vacuum regulator solenoid	Figure F083-13
	2002–03	All	Differential feedback EGR	Figure F083-15
			Vacuum regulator solenoid	Figure F083-16
	2004–05	with tube mounted DPFE sensor	Differential Pressure Feedback EGR	Figure F083-18 Table F083-3 Table F083-4
		without tube mounted DPFE sensor	Differential Pressure Feedback EGR	Figure F083-19 Table F083-3 Table F083-4
		with conventional EGR/EVR system	Vacuum Regulator Solenoid	Figure F083-20 Table F083-3 Table F083-4
	2006–08	All	EGR system module (ESM)	Figure F083-22
Tracer	1996	All	Vacuum regulator solenoid	Figure F083-5
	1996–99	All	Differential feedback EGR	Figure F083-1
	1997–99	All	Vacuum regulator solenoid	Figure F083-13
Zephyr	2006	All	EGR system module (ESM)	Figure F083-22
			Electric EGR assmbly	Figure F083-23

Table F083-2 Truck, Van, and Sport Utility (part 1 of 4)

MODEL	YEAR	ENGINE	CONNECTOR	FIGURE
Aerostar	1996–97	All	Differential feedback EGR	Figure F083-1
		All	Vacuum regulator solenoid	Figure F083-13
Bronco	1996	All	Vacuum regulator solenoid	Figure F083-6
E-Series	1996	5.0, 5.8L, 7.5L	Vacuum Regulator Solenoid	Figure F083-6
		4.9L	Vacuum Regulator Solenoid	Figure F083-13
		5.0L	Exhaust valve position sensor	Figure F083-12
	1997	4.2L, 4.6L, 5.4L	Vacuum regulator solenoid	Figure F083-13
	1998–2001	All	Vacuum regulator solenoid	Figure F083-13
	2002–03	All	Differential feedback EGR	Figure F083-15
			Vacuum regulator solenoid	Figure F083-16
	2004–06 Except 4.6L	with tube mounted DPFE sensor	Differential Pressure Feedback EGR	Figure F083-18
				Table F083-3
				Table F083-4
2004–06 Except 4.6L	without tube mounted DPFE sensor	Differential Pressure Feedback EGR	Figure F083-19	
			Table F083-3 Table F083-4	
2004–06 Except 4.6L	with conventional EGR/EVR system	Vacuum Regulator Solenoid	Figure F083-20	
			Table F083-3 Table F083-4	
2006–08 4.6L	All	EGR system module (ESM)	Figure F083-31	
Escape	2001–04	2.0L	Electronic Vacuum Regulator	Figure F083-32
		3.0L		Figure F083-33
		2.0L, 3.0L	Delta Pressure Feedback	Figure F083-34
	2005–08	2.0L, 3.0L	Electronic Vacuum Regulator	Figure F083-35
			Delta Pressure Feedback	Figure F083-36
		2.3L, 2.3L Hybrid	Electric EGR assmbly	Figure F083-37
Excursion	1998–2001	All	Vacuum Regulator solenoid	Figure F083-13
	2002–03	All	Differential feedback EGR	Figure F083-15
			Vacuum Regulator solenoid	Figure F083-16
	2004–05	with tube mounted DPFE sensor	Differential Pressure Feedback EGR	Figure F083-18
				Table F083-3
				Table F083-4
	2004–05	without tube mounted DPFE sensor	Differential Pressure Feedback EGR	Figure F083-19
Table F083-3 Table F083-4				
2004–05	with conventional EGR/EVR system	Vacuum regulator Solenoid	Figure F083-20	
			Table F083-3 Table F083-4	

Table F083-2 Truck, Van, and Sport Utility (part 2 of 4)

MODEL	YEAR	ENGINE	CONNECTOR	FIGURE
Expedition	1996–2001	All	Differential feedback EGR	Figure F083-1
	1997–2001	All	Vacuum regulator solenoid	Figure F083-13
	2002–03	All	Differential feedback EGR	Figure F083-15
			Vacuum regulator solenoid	Figure F083-16
	2004	with tube mounted DPFE sensor	Differential Pressure Feedback EGR	Figure F083-18 Table F083-3 Table F083-4
			Differential Pressure Feedback EGR	Figure F083-19 Table F083-3 Table F083-4
Vacuum regulator Solenoid			Figure F083-20 Table F083-3 Table F083-4	
Explorer, Sport Trac	1996–97	All	Vacuum regulator solenoid	Figure F083-13
	1996–2001	All	Differential feedback EGR	Figure F083-1
	1997	5.0L (early)	Exhaust valve position sensor	Figure F083-12
	1998–2001	All	Vacuum regulator solenoid	Figure F083-13
	2002–03	All	Differential feedback EGR	Figure F083-2
	2004–05	with tube mounted DPFE sensor	Differential Pressure Feedback EGR	Figure F083-18 Table F083-3 Table F083-4
			Differential Pressure Feedback EGR	Figure F083-19 Table F083-3 Table F083-4
			Vacuum regulator Solenoid	Figure F083-20 Table F083-3 Table F083-4
	2006–08	All	EGR system module (ESM)	Figure F083-22
	2007–08	4.0L	Electronic Vacuum Regulator	Figure F083-38
Delta Pressure Feedback			Figure F083-39	
F-Series	1996	4.9L, 5.0L, 5.8L, 5.5L	Vacuum regulator solenoid	Figure F083-6
		5.8L over 8500 GVW	Exhaust valve position sensor	Figure F083-12
		7.0L	Exhaust valve position sensor	Figure F083-12
	1996–2001	All	Differential feedback EGR	Figure F083-1
	1997	4.2L, 4.6L, 5.4L	Vacuum regulator solenoid	Figure F083-13
			Vacuum regulator solenoid	Figure F083-4
			Exhaust valve position sensor	Figure F083-12
	1998–2001	All	Vacuum regulator solenoid	Figure F083-13
	2002–03	All	Differential feedback EGR	Figure F083-15
			Vacuum regulator solenoid	Figure F083-16
2004–06	All	EGR system module (ESM)	Figure F083-22	

Table F083-2 Truck, Van, and Sport Utility (part 3 of 4)

MODEL	YEAR	ENGINE	CONNECTOR	FIGURE
F-150 Lightning	2003	All	Differential feedback EGR	Figure F083-2
	2004–05	with tube mounted DPFE sensor	Differential Pressure Feedback EGR	Figure F083-18 Table F083-3 Table F083-4
		without tube mounted DPFE sensor	Differential Pressure Feedback EGR	Figure F083-19 Table F083-3 Table F083-4
		with conventional EGR/EVR system	Vacuum regulator Solenoid	Figure F083-20 Table F083-3 Table F083-4
F-Super Duty	1996	7.5L	Exhaust valve position sensor	Figure F083-12
	1997	5.8L, 7.5L	Exhaust valve position sensor	Figure F083-12
Mariner	2005–08	2.0L, 3.0L	Electronic Vacuum Regulator	Figure F083-35
			Delta Pressure Feedback	Figure F083-36
		2.3L, 2.3L Hybrid	Electric EGR assmby	Figure F083-37
Mountaineer	1997	All	Vacuum regulator solenoid	Figure F083-13
	1997–2001	All	Differential feedback EGR	Figure F083-1
	1997	5.0L (early)	Exhaust valve position sensor	Figure F083-12
	1998–2001	All	Vacuum regulator solenoid	Figure F083-13
	2002–03	All	Differential feedback EGR	Figure F083-2
	2004–05	with tube mounted DPFE sensor	Differential Pressure Feedback EGR	Figure F083-18 Table F083-3 Table F083-4
		without tube mounted DPFE sensor	Differential Pressure Feedback EGR	Figure F083-19 Table F083-3 Table F083-4
		with conventional EGR/EVR system	Vacuum regulator Solenoid	Figure F083-20 Table F083-3 Table F083-4
	2006–08	All	EGR system module (ESM)	Figure F083-22
	2007–08	4.0L	Electronic Vacuum Regulator	Figure F083-38
Delta Pressure Feedback			Figure F083-39	
Navigator	1998–2001	All	Differential feedback EGR	Figure F083-1
		All	Vacuum regulator solenoid	Figure F083-13
	2002–03	All	Differential feedback EGR	Figure F083-15
			Vacuum regulator solenoid	Figure F083-16
	2004	with tube mounted DPFE sensor	Differential Pressure Feedback EGR	Figure F083-18 Table F083-3 Table F083-4
		without tube mounted DPFE sensor	Differential Pressure Feedback EGR	Figure F083-19 Table F083-3 Table F083-4
		with conventional EGR/EVR system	Vacuum regulator Solenoid	Figure F083-20 Table F083-3 Table F083-4

Table F083-2 Truck, Van, and Sport Utility (part 4 of 4)

MODEL	YEAR	ENGINE	CONNECTOR	FIGURE
Ranger	1996–97	All	Vacuum regulator solenoid	Figure F083-13
	1996–2001	All	Differential feedback EGR	Figure F083-1
	1998–2001	All	Vacuum regulator solenoid	Figure F083-13
	2001–08	2.3L	Electric EGR motor valve	Figure F083-3
			EGR motor harness	Figure F083-17
	2002–03	All	Differential feedback EGR	Figure F083-15
			Vacuum regulator solenoid	Figure F083-16
	2004–05	with tube mounted DPFE sensor	Differential Pressure Feedback EGR	Figure F083-18
				Table F083-3
Table F083-4				
2004–05	without tube mounted DPFE sensor	Differential Pressure Feedback EGR	Figure F083-19	
			Table F083-3	
			Table F083-4	
Windstar	1996	3.0L	Vacuum regulator solenoid	Figure F083-6
	1996–97	All	Vacuum regulator solenoid	Figure F083-13
	1996–2001	All	Differential feedback EGR	Figure F083-1
	1998–2001	All	Vacuum regulator solenoid	Figure F083-13

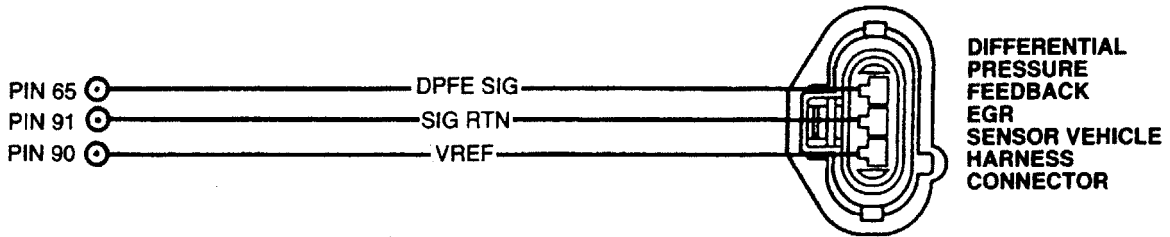
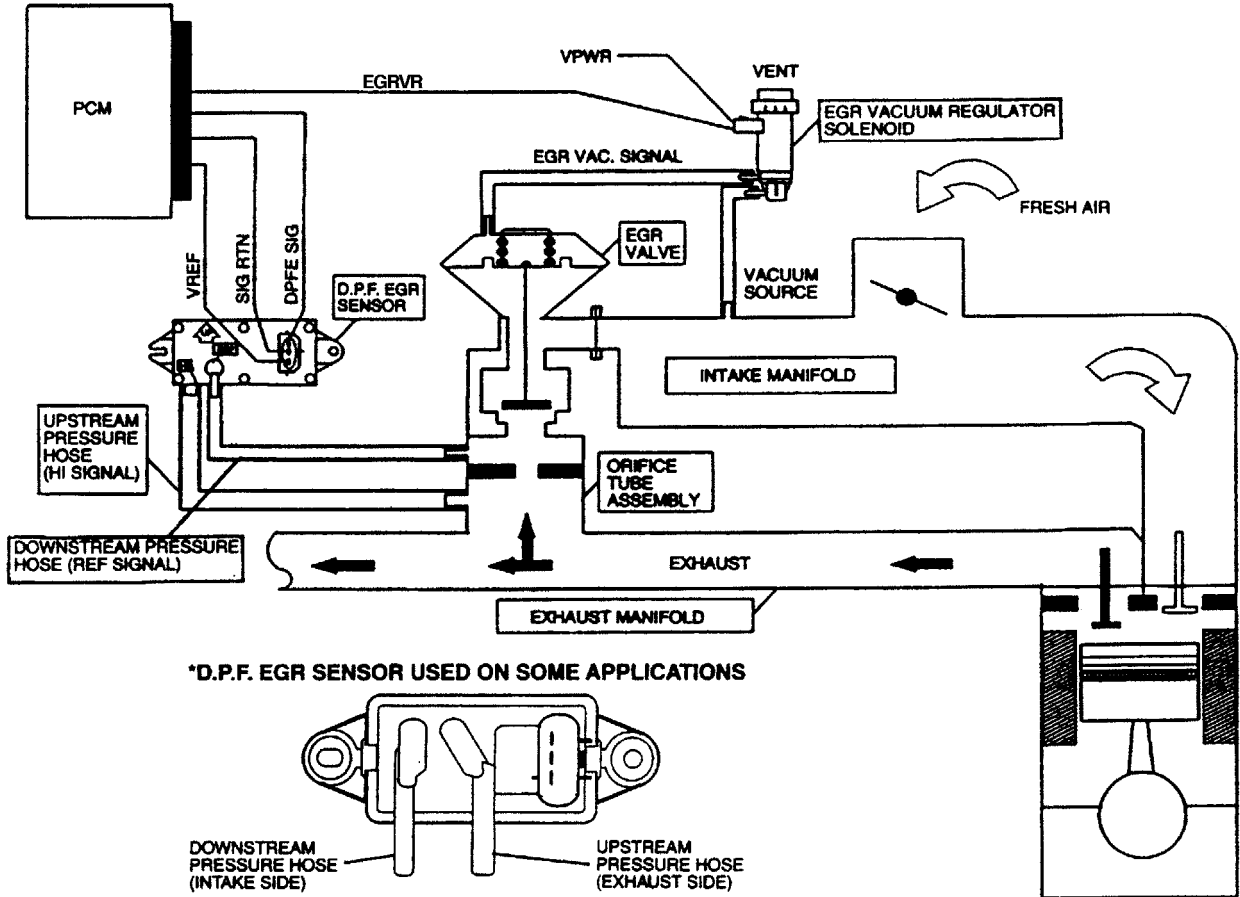

Figure F083-1 See tables for applications

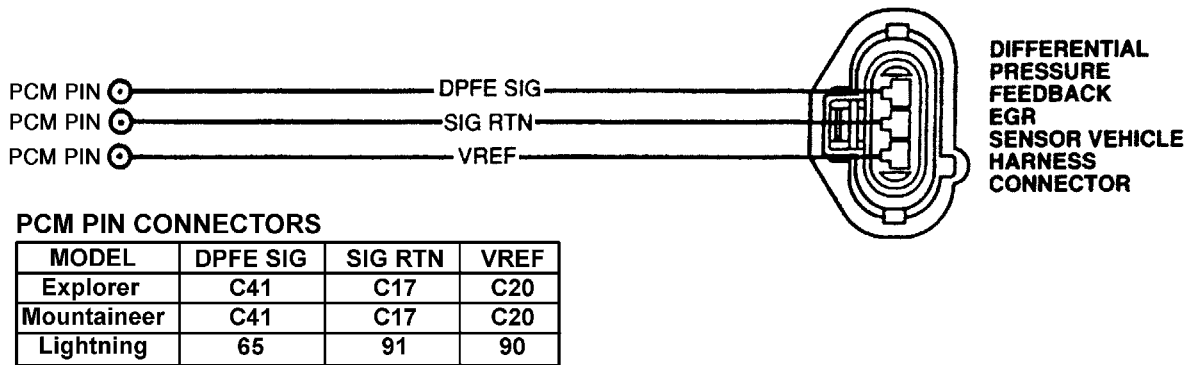

Figure F083-2 See tables for applications

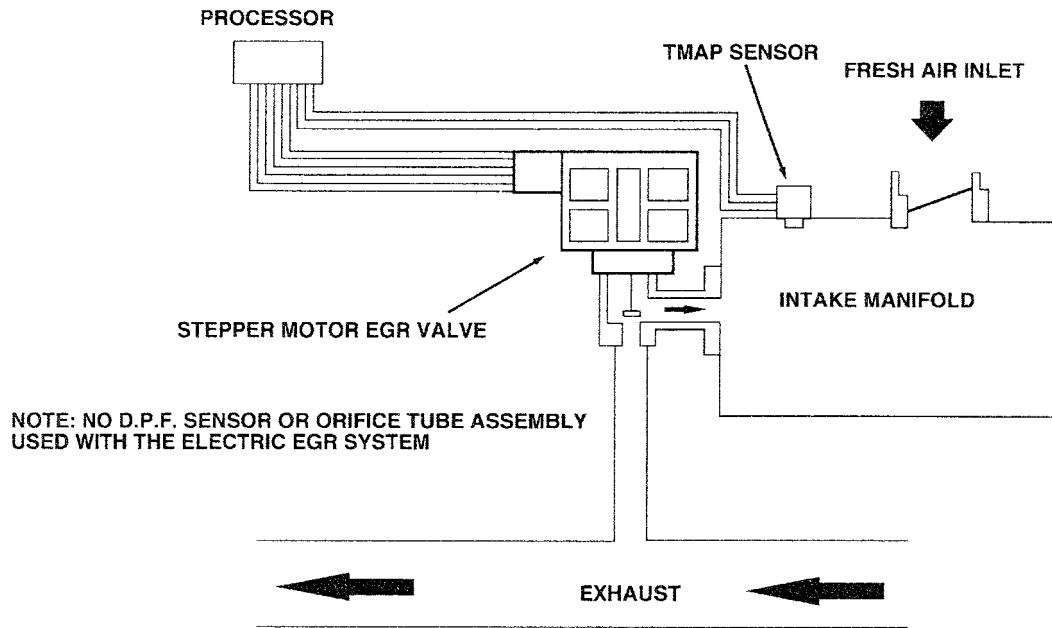

Figure F083-3 See tables for applications

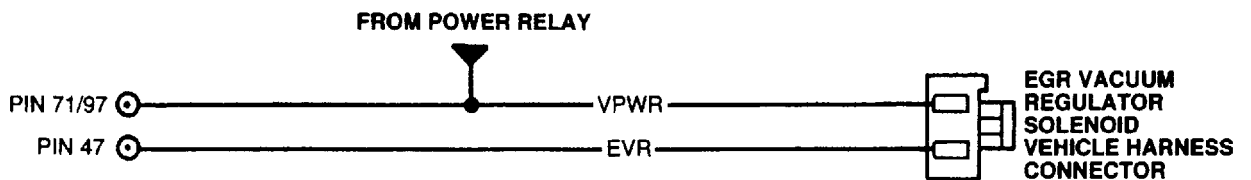

Figure F083-4 See tables for applications

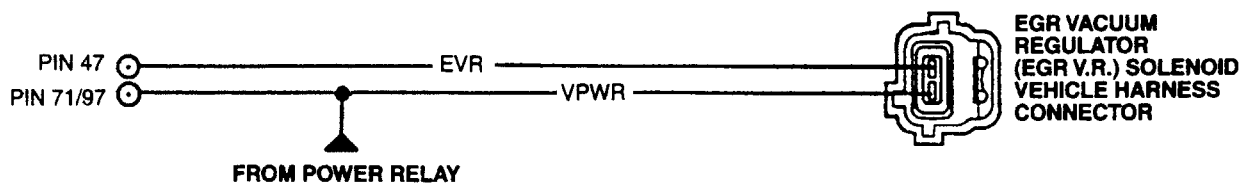

Figure F083-5 See tables for applications

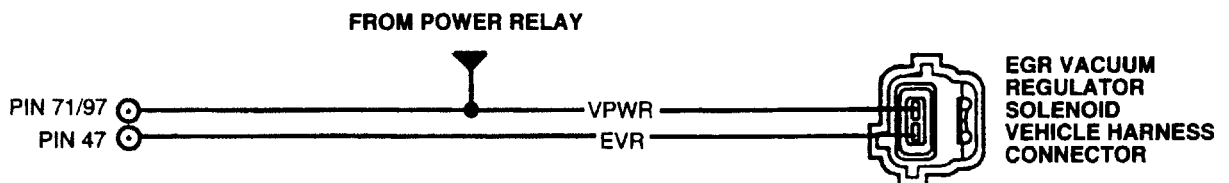

Figure F083-6 See tables for applications

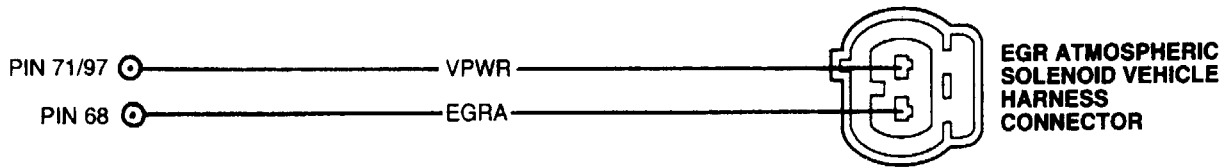

Figure F083-7 See tables for applications

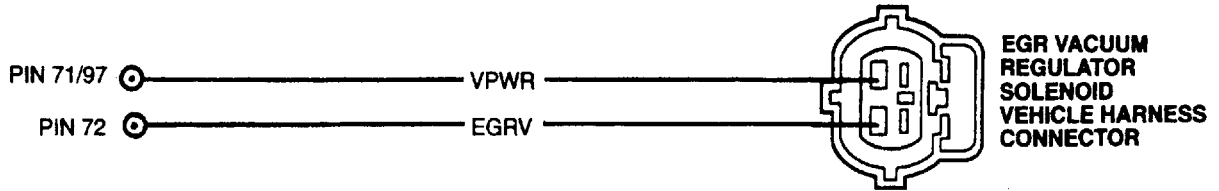

Figure F083-8 See tables for applications

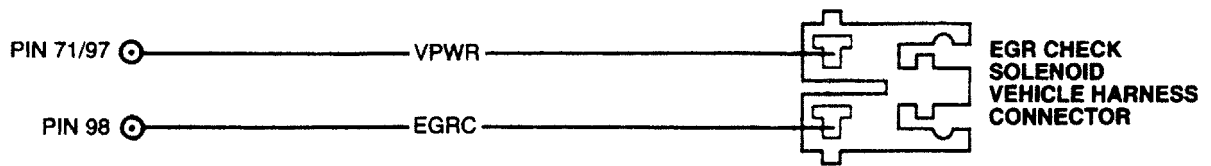

Figure F083-9 See tables for applications

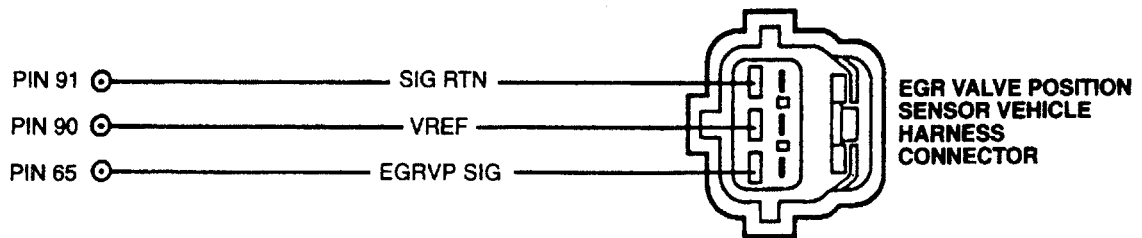

Figure F083-10 See tables for applications

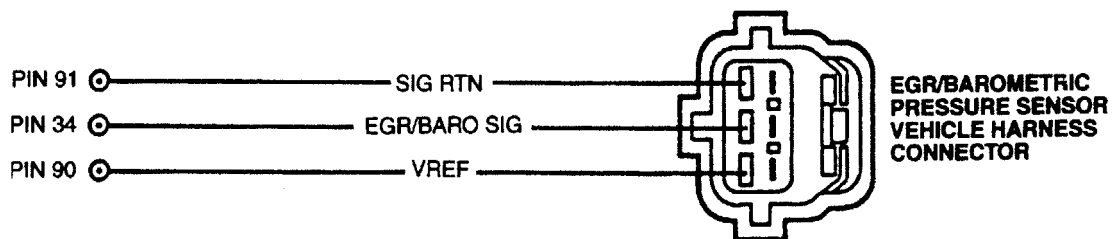

Figure F083-11 See tables for applications

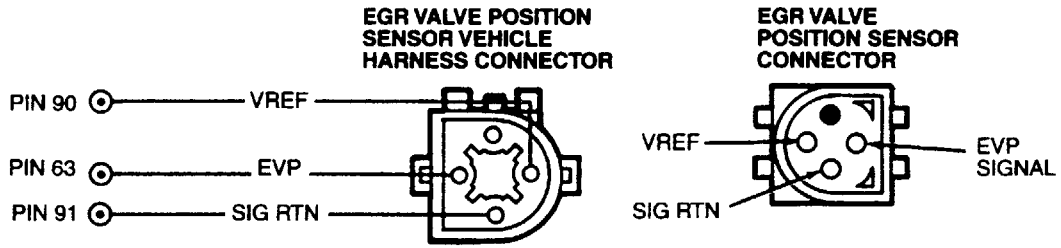

Figure F083-12 See tables for applications

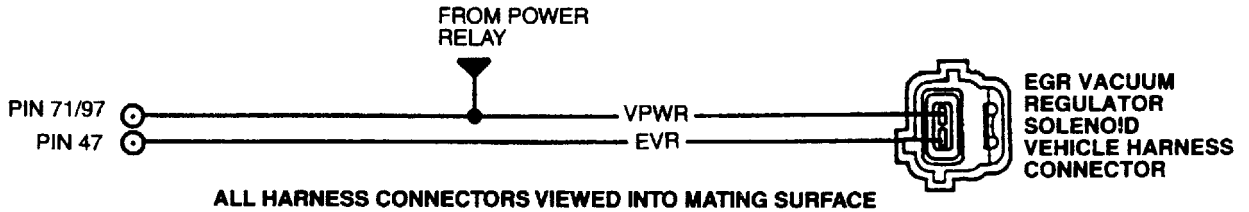

Figure F083-13 See tables for applications

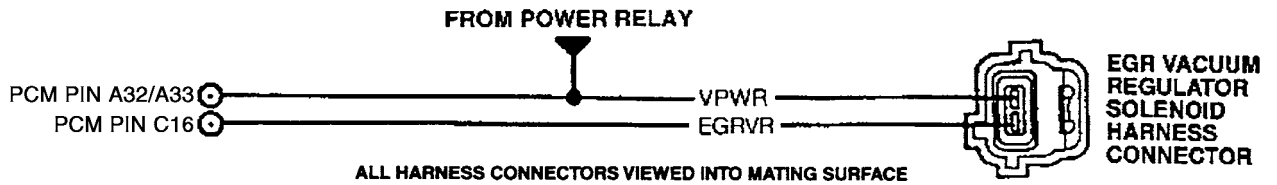
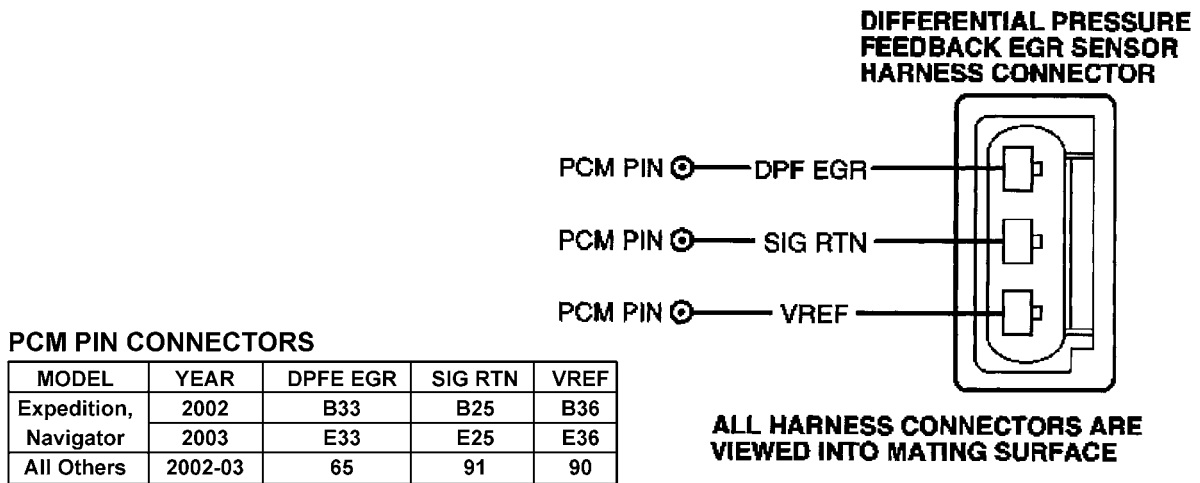

Figure F083-14 See tables for applications



PCM PIN CONNECTORS

MODEL	YEAR	DPFE EGR	SIG RTN	VREF
Expedition, Navigator	2002	B33	B25	B36
	2003	E33	E25	E36
All Others	2002-03	65	91	90

Figure F083-15 See tables for applications

PCM PIN CONNECTORS

MODEL	YEAR	EGRVR	VPWR
Explorer,	2002	C16	B68
Mountaineer	2003	E16	B32/B33
Expedition,	2002	B22	A34/A36
Navigator	2003	E22	B34/B46
All Others	2002-03	47	71

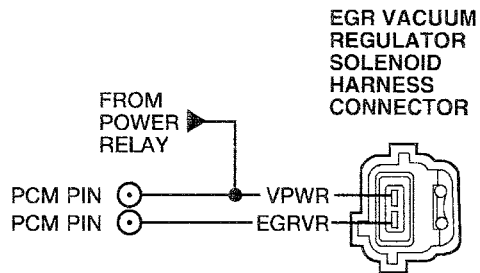
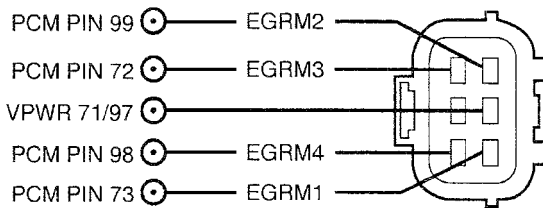

Figure F083-16 See tables for applications

ELECTRIC EGR MOTOR HARNESS CONNECTOR



ALL HARNESS CONNECTORS ARE VIEWED INTO MATING SURFACE

Figure F083-17 See tables for applications

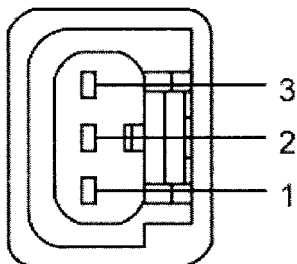

Vehicle	Connector	Pin	Circuit
All models with a tube mounted DPFE sensor	A	3	DPFEGR
		2	SIGRTN
		1	VREF

Figure F083-18 See tables for applications

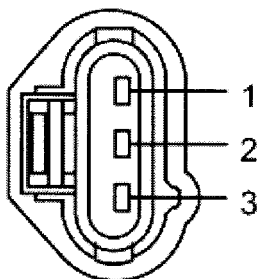

Connector	Pin	Circuit
B	1	DPFEGR
	2	SIGRTN
	3	VREF

Figure F083-19 See tables for applications

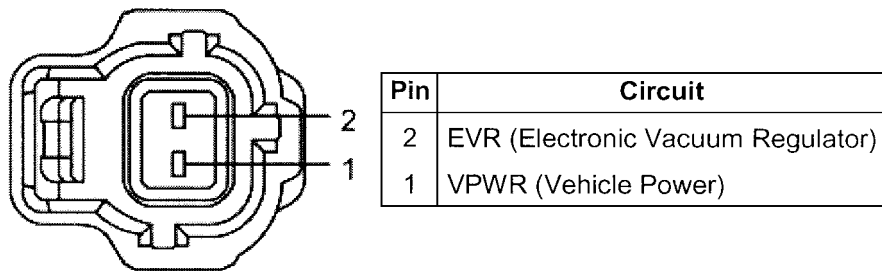

Figure F083-20 See tables for applications

Table F083-3 2004 Powertrain Control Module (PCM) EVR, DPFE Pinouts and circuits

Vehicle	Connector	Pin	Circuit
E-Series Explorer Mountaineer Mustang	170 Pin	B47 E63 E57 E58 E21	PWRGND EVR VREF SIGRTN DPFEGR
Escape Mariner	150 Pin (50-50-50)	B47 E27 E40 E41 E44	PWRGND EVR VREF SIGRTN DPFEGR
F-150	190 Pin	B67 E63 E57 E58 E21	PWRGND EVR VREF SIGRTN DPFEGR
Freestar Ford GT Monterey Ranger Taurus	104 Pin	103 47 90 91 65	PWRGND EVR VREF SIGRTN DPFEGR
Lincoln LS	150 Pin (60-32-58)	B24 E16 E14 E17 E41	PWRGND EVR VREF SIGRTN DPFEGR
All Other Vehicles	150 Pin (50-50-50)	B47 E6 E40 E41 E44	PWRGND EVR VREF SIGRTN DPFEGR

Table F083-4 2005 Powertrain Control Module (PCM) EVR, DPFE Pinouts and circuits

Vehicle	Connector	Pin	Circuit
Aviator	150 Pin (60-32-58)	B24 B16 E20 E17 E41	PWRGND EVR VREF SIGRTN DPFEGR
Crown Victoria Explorer Five Hundred Freestyle Grand Marquis Montego Mountaineer Town Car	150 Pin (50-50-50)	B47 E6 E40 E41 E44	PWRGND EVR VREF SIGRTN DPFEGR
E-Series F-Super Duty	170 Pin	B47 E63 E57 E58 E21	PWRGND EVR VREF SIGRTN DPFEGR
Escape Mariner	150 Pin (50-50-50)	B47 E27 E40 E41 E44	PWRGND EVR VREF SIGRTN DPFEGR
Excursion	104 Pin	3 47 90 91 65	PWRGND EVR VREF SIGRTN DPFEGR
F-150	190 Pin	3 47 90 91 65	PWRGND EVR VREF SIGRTN DPFEGR
Lincoln LS Thunderbird	150 Pin (60-32-58)	B24 E16 E14 E17 E41	PWRGND EVR VREF SIGRTN DPFEGR
Mustang	170 Pin	B47 E63 E24 E33 E21	PWRGND EVR VREF SIGRTN DPFEGR
All other vehicles	104 Pin	103 47 90 91 65	PWRGND EVR VREF SIGRTN DPFEGR

Electric EGR Motor Connector

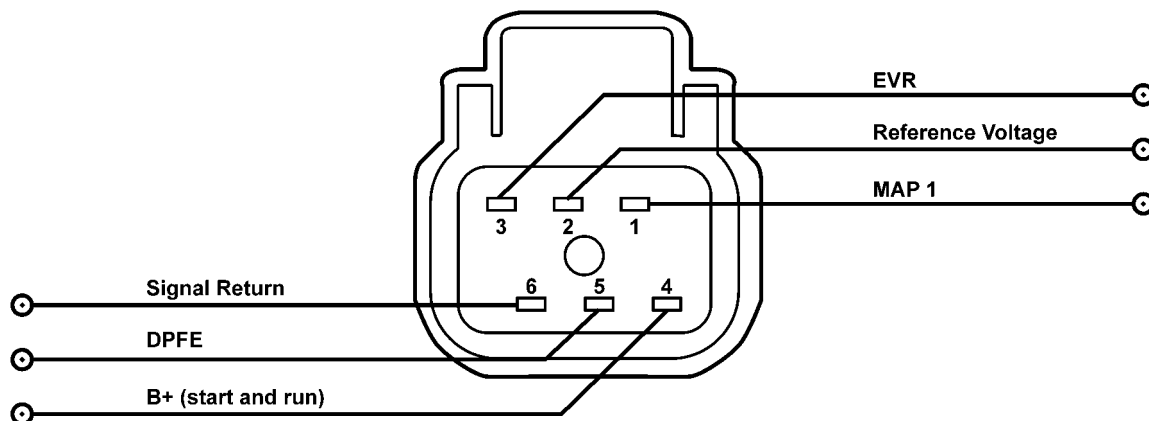

Figure F083-21 See tables for applications

EGR System Module (ESM) Connector

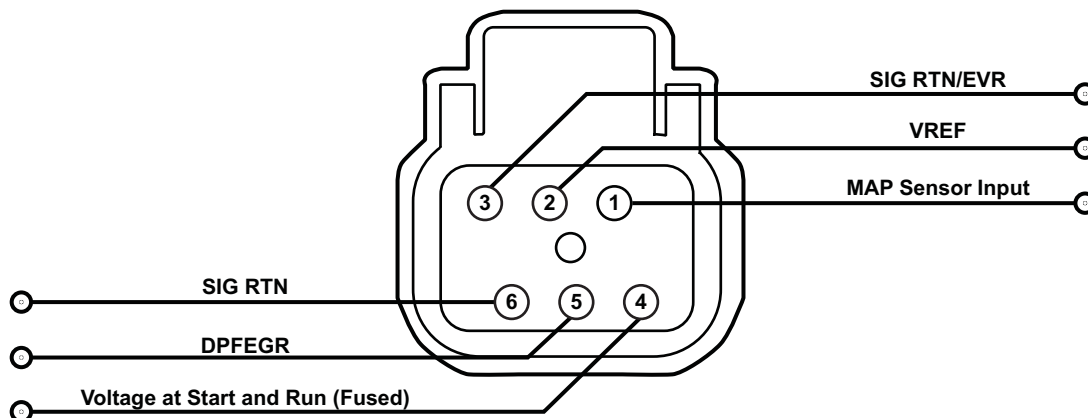

Figure F083-22 See Table F083-5 for applications

Table F083-5 2006 EGR system module (ESM) connector PCM pin circuits by model (part 1 of 2)

Vehicle	Engine	PCM Type	Pin	Circuit
Freestar, Ford GT, Monterey, Ranger, Taurus	—	104 Pin	103	PWRGND
			47	EVR
			90	VREF
			91	SIGRTN
			65	DPFEGR
Escape, Mariner	—	150 Pin (50-50-50)	B47	PWRGND
			E27	EVR
			E40	VREF
			E41	SIGRTN
			E44	DPFEGR

Table F083-5 2006 EGR system module (ESM) connector PCM pin circuits by model (part 2 of 2)

Vehicle	Engine	PCM Type	Pin	Circuit
All except Escape, Mariner	—	150 Pin (50-50-50)	B47	PWRGND
			E6	EVR
			E40	VREF
			E41	SIGRTN
			E44	DPFEGR
LS	—	150 Pin (60-32-58)	B24	PWRGND
			E16	EVR
			E14	VREF
			E17	SIGRTN
E-Series, Explorer, Mountaineer, Mustang	—	170 Pin	B47	PWRGND
			E63	EVR
			E57	VREF
			E58	SIGRTN
F-150	—	190 Pin	E21	DPFEGR
			B67	PWRGND
			E63	PWRGND
			E63	EVR
			E57	VREF
			E58	SIGRTN
			E21	DPFEGR

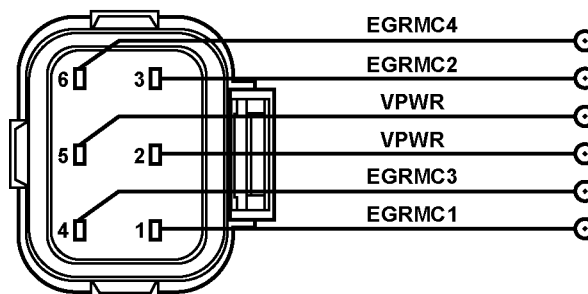
Electric EGR Assembly Connector**Figure F083-23** See [Table F083-6](#) for applications**Table F083-6** 2006 Electric EGR assembly connector PCM pin circuits by model (part 1 of 2)

Vehicle	Engine	PCM Type	Pin	Circuit
Ranger	—	104 Pin	71	VPWR
			98	EGMMC4
			72	EGMMC3
			99	EGMMC2
			73	EGMMC1
Fusion, Milan, Zephyr	—	140 Pin	B51	VPWR
			E9	EGMMC4
			E8	EGMMC3
			E7	EGMMC2
			E6	EGMMC1

Table F083-6 2006 Electric EGR assembly connector PCM pin circuits by model (part 2 of 2)

Vehicle	Engine	PCM Type	Pin	Circuit
All other models	—	150 Pin (50-50-50)	B35	VPWR
			E11	EGMMC4
			E10	EGMMC3
			E9	EGMMC2
			E8	EGMMC1

EGR System Module (ESM) Connector

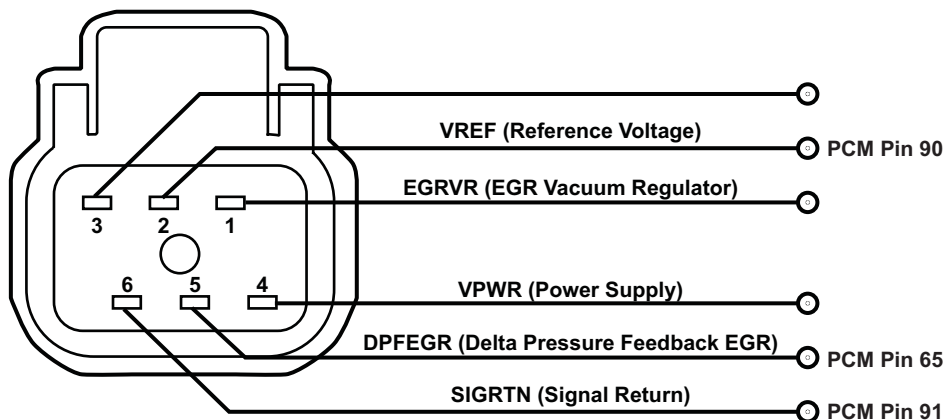

Figure F083-24 See tables for applications

EGR System Module (ESM) Connector

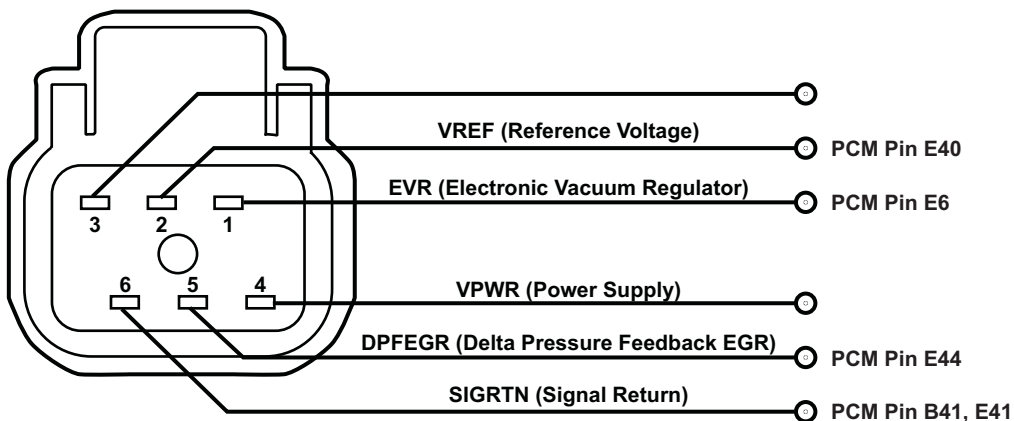

Figure F083-25 See tables for applications

EGR System Module (ESM) Connector

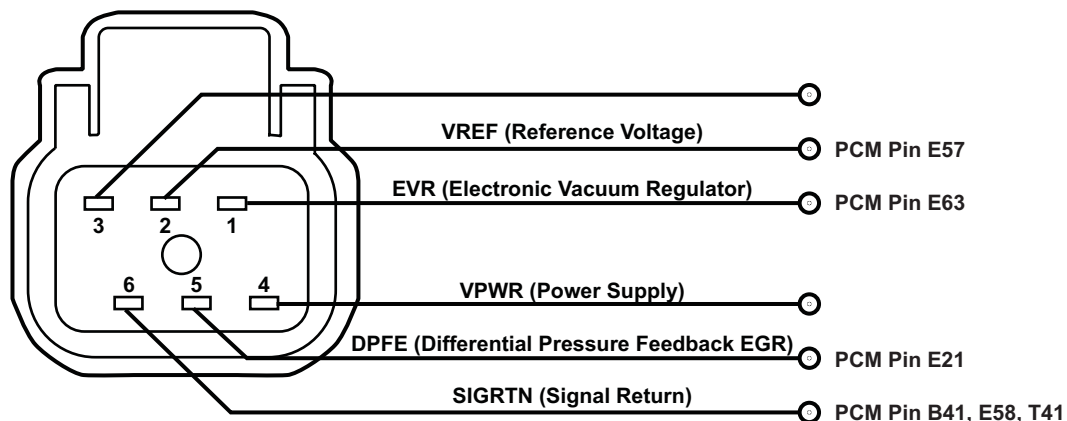

Figure F083-26 See tables for applications

Electric EGR Assembly Connector

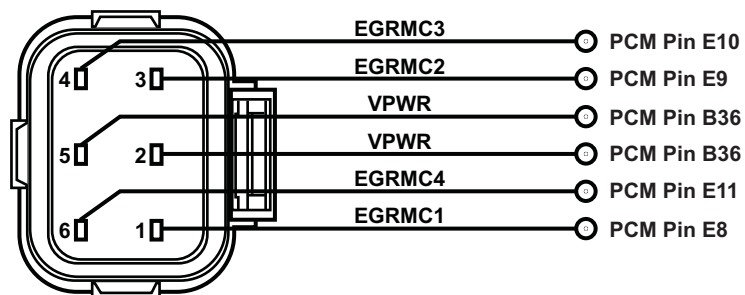

Figure F083-27 See tables for applications

Electric EGR Assembly Connector

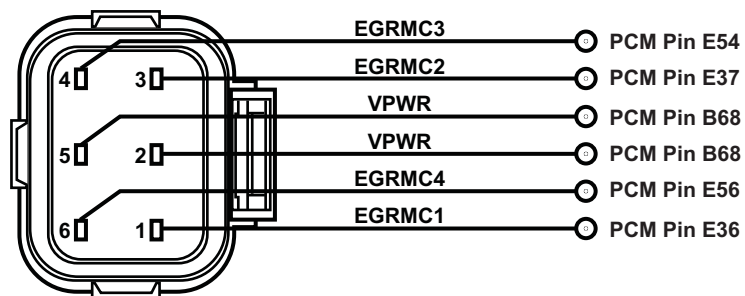

Figure F083-28 See tables for applications

EGR System Module (ESM) Connector

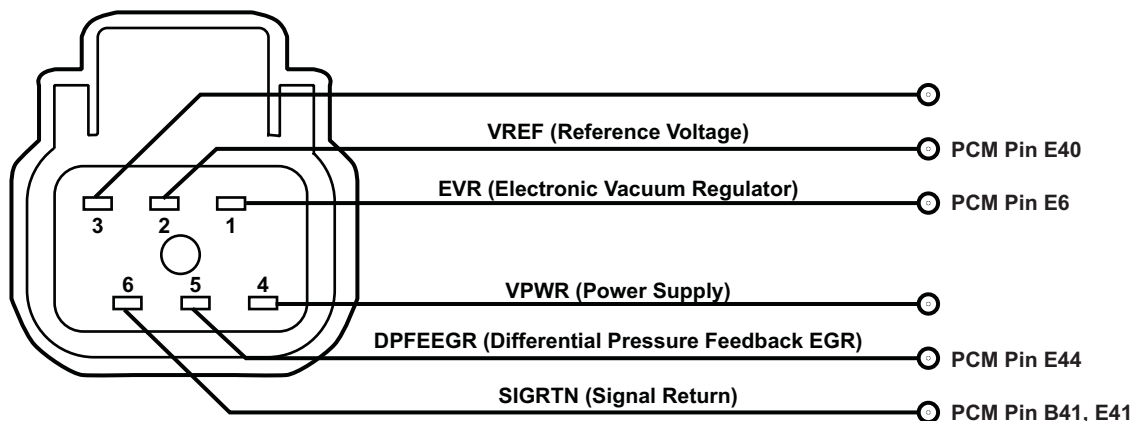

Figure F083-29 See tables for applications

Electric EGR Assembly Connector

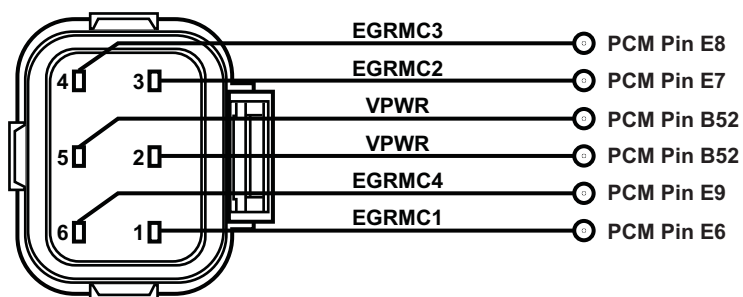

Figure F083-30 See tables for applications

EGR System Module (ESM) Connector

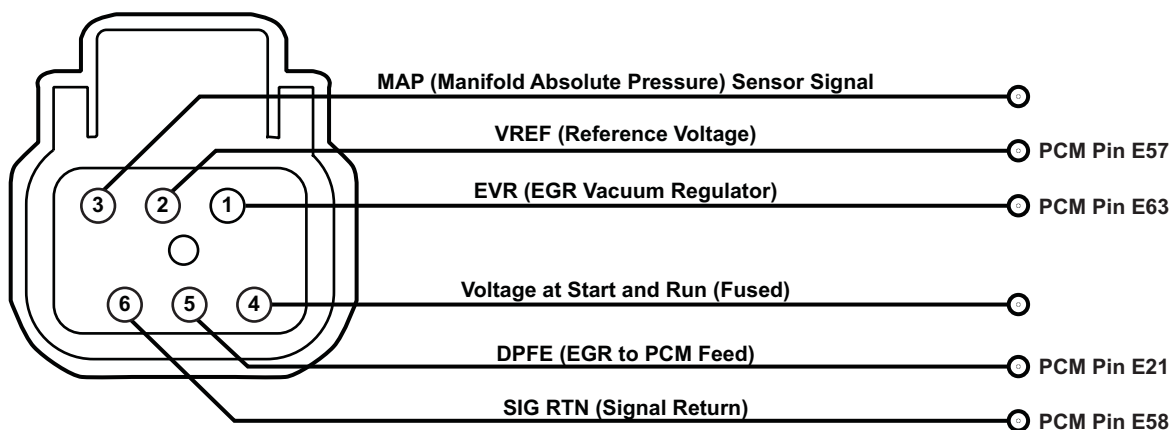

Figure F083-31 See tables for applications

Electronic Vacuum Regulator (EVR) Solenoid Connector

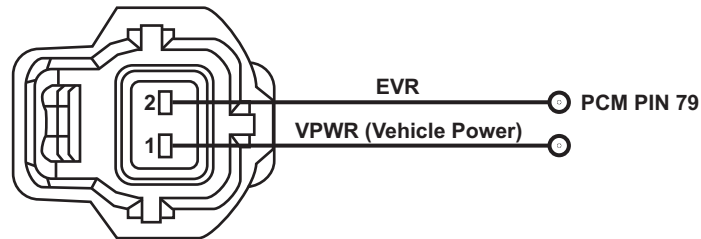

Figure F083-32 See tables for applications

Electronic Vacuum Regulator (EVR) Solenoid Connector

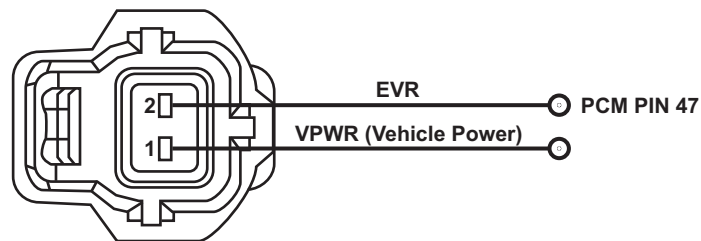

Figure F083-33 See tables for applications

Delta Pressure Feedback EGR (DPFE) Connector

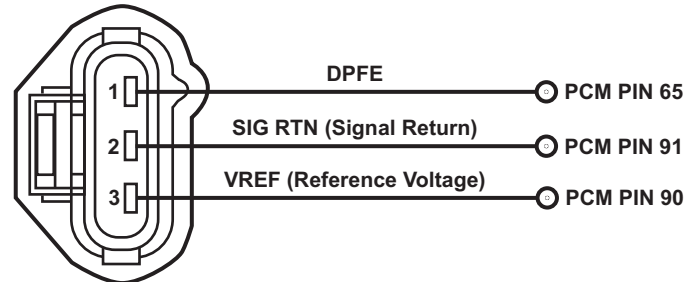

Figure F083-34 See tables for applications

Electronic Vacuum Regulator (EVR) Solenoid Connector

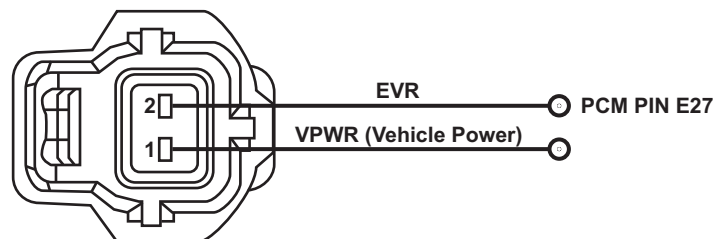

Figure F083-35 See tables for applications

Delta Pressure Feedback EGR (DPFE) Connector

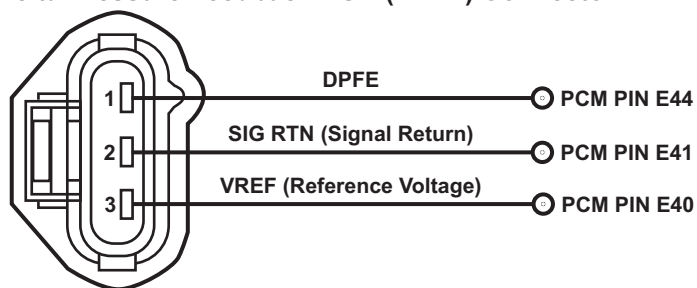

Figure F083-36 See tables for applications

Electric EGR Assembly Connector

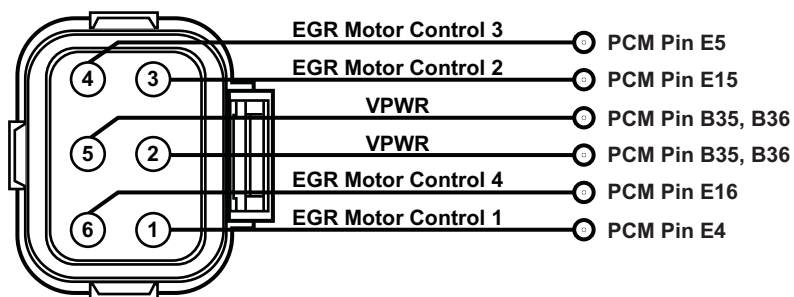

Figure F083-37 See tables for applications

Electronic Vacuum Regulator (EVR) Solenoid Connector

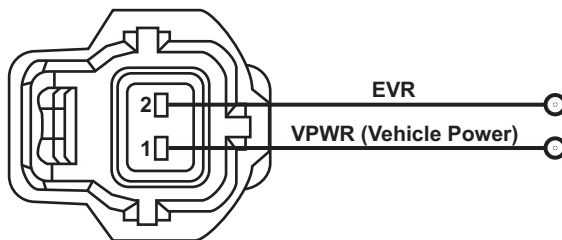

Figure F083-38 See tables for applications

Delta Pressure Feedback EGR (DPFE) Connector

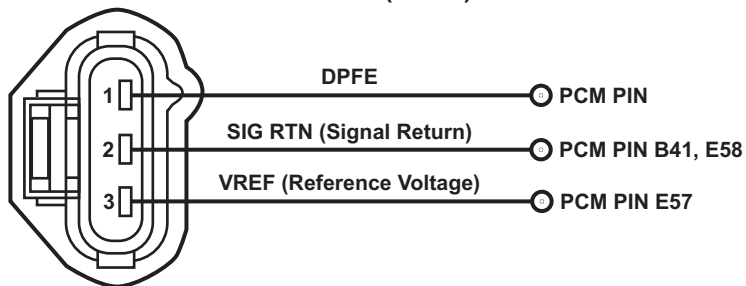

Figure F083-39 See tables for applications